

Cores Design

CHARACTER OF IRON POWDER CORES:

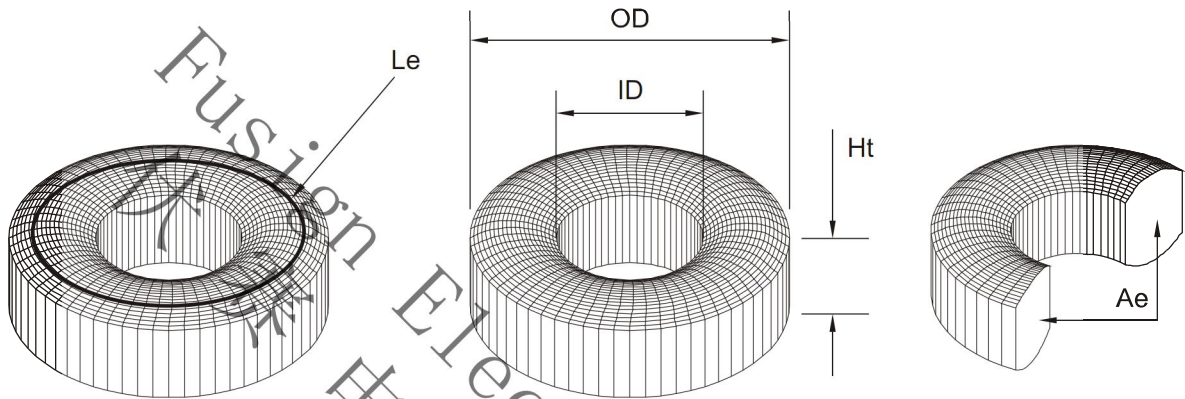

SYMBOL AND FORMULA

$$A_e = \frac{OD-ID}{2} \times H_t \quad L = \frac{4\pi \mu_e A_e}{L_e} \times N^2$$

$$L_e = \frac{OD+ID}{2} \times \pi$$

$$N = \sqrt{\frac{L}{A_L}} \quad A_L = \frac{L}{N^2}$$

A_e —Core cross section area(cm^2)

L_e —Effective magnetic path length(cm)

N —Winding turns

A_L —Inductance rated value (nH/ N^2) of one core,
during frequency 10KHz and AC flux density
10 gauss(1mT)

L —Inductance

μ_e —Effective Permeability

π —3.14